

**STANDARD FEATURES:**

- PAINTED AIR MOTOR WITH MUFFLER
- HELICAL GEARBOX - 5:1 REDUCTION RATIO
- 350 RPM NOMINAL OUTPUT
- ADJUSTABLE BRIDGE MOUNT
- 316SS WETTED PARTS
- 1" X 36" FMB SHAFT STANDARD
- SINGLE OR DUAL FOLDING IMPELLERS
- WITH SET SCREW ATTACHMENT
- SPEED CONTROL VALVE

AIR CONSUMPTION	
1 HP	40 CFM @ 80 PSI
2 HP	60 CFM @ 70 PSI
3 HP	90 CFM @ 100 PSI

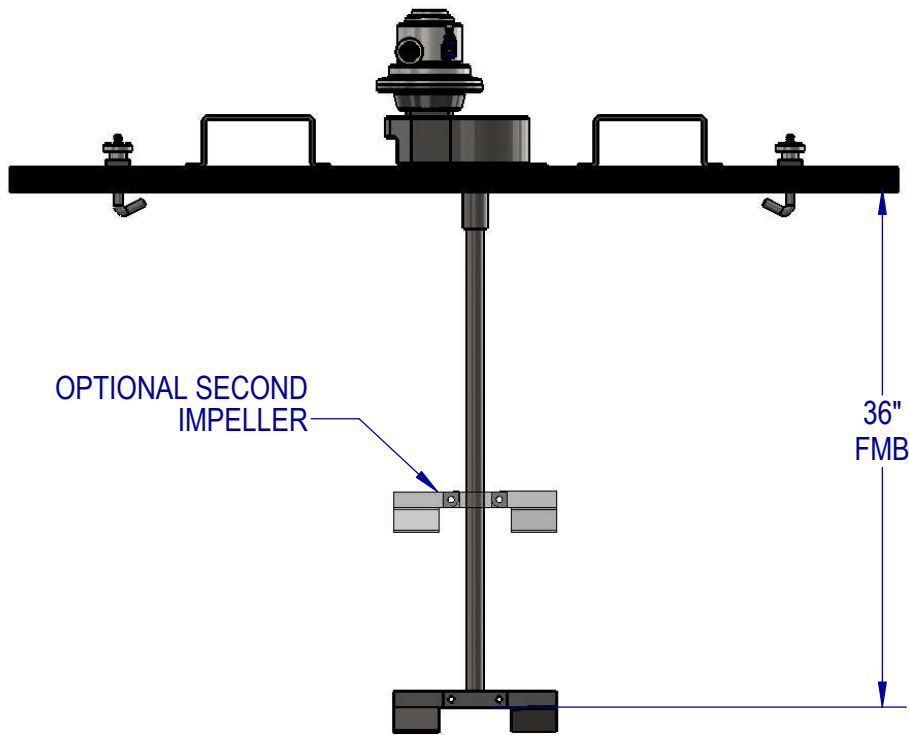

- OPTIONS:**
- FILTER/REGULATOR/LUBRICATOR (FRL)
  - 32 Ra FINISH ON WETTED PARTS
  - FORK LIFT CHANNELS
  - TOTE CAP WITH VITON FLOATING SEAL

EST WT: 70-86 LBS (DEPENDING ON HP AND OPTIONS)

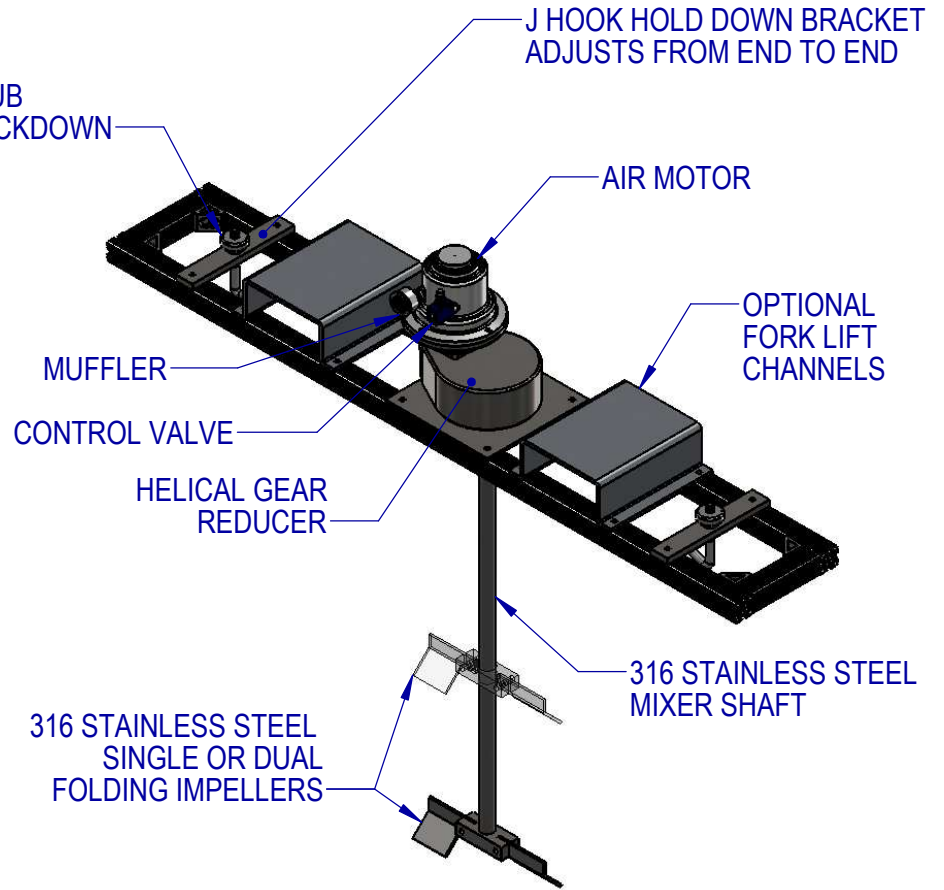

**BRIDGE MOUNT TOTE MIXERS MOUNT TO CAGE STYLE TOTES UP TO 52" WIDE**

	NAME	DATE
DRAWN	JDF	6/10/13
CHECKED	PIC	6/10/13



**PROPRIETARY AND CONFIDENTIAL**

THE INFORMATION CONTAINED IN THIS DRAWING IS THE SOLE PROPERTY OF FUSION FLUID EQUIPMENT LLC. ANY REPRODUCTION IN PART OR AS A WHOLE WITHOUT THE WRITTEN PERMISSION OF FUSION FLUID EQUIPMENT LLC IS PROHIBITED.

WHILE FUSION FLUID EQUIPMENT LLC STRIVES TO MAINTAIN THE INTEGRITY OF A DESIGN AS APPROVED, FUSION FLUID EQUIPMENT LLC RETAINS THE RIGHT TO MAKE MODIFICATIONS DURING THE MANUFACTURING PROCESS TO IMPROVE FIT, FORM, AND FUNCTION OF THE DESIGN WITHOUT CUSTOMER NOTIFICATION OR CONSENT.

UNLESS OTHERWISE SPECIFIED:  
DIMENSIONS ARE IN INCHES.  
NO TOLERANCE IS IMPLIED.  
DO NOT SCALE DRAWING

TITLE:		
BRIDGE MOUNT TOTE MIXER GEAR DRIVE AIR MOTOR		
SIZE	DWG. NO.	REV
A	SALES-BGA-#T	A
SCALE: 1:12	WEIGHT:	SHEET 1 OF 1