

**STANDARD FEATURES:**

- PAINTED THREE PHASE 220/440/60 ELECTRIC MOTOR
- HELICAL GEARBOX - 5:1 REDUCTION RATIO
- 350 RPM NOMINAL OUTPUT
- ADJUSTABLE BRIDGE MOUNT
- 316SS WETTED PARTS
- 1" X 36" FMB SHAFT
- SINGLE OR DUAL FOLDING IMPELLERS
- WITH SET SCREW ATTACHMENT

**OPTIONS:**

- SINGLE PHASE TEFC MOTOR
- PREWIRED W/ TOGGLE SWITCH, CORD AND 110V PLUG
- SINGLE SPEED EXPLOSION PROOF MOTOR
- 32 Ra FINISH ON ALL WETTED PARTS
- FORK LIFT CHANNELS
- TOTE CAP WITH VITON FLOATING SEAL

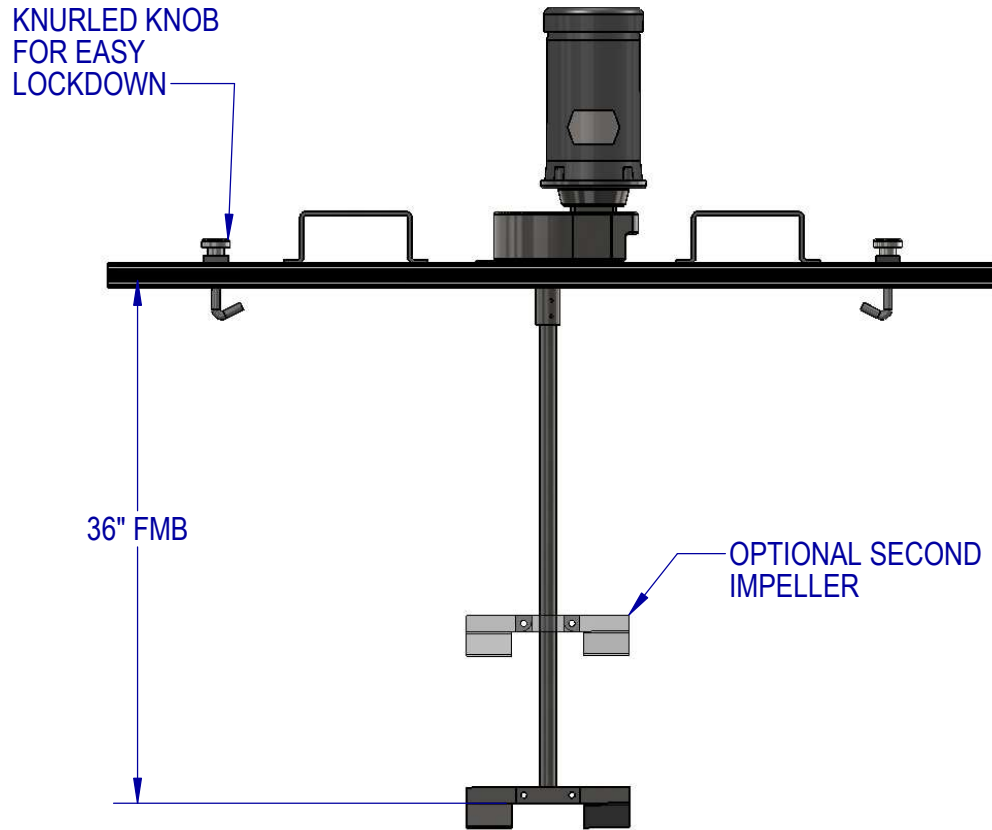

BRIDGE MOUNT TOTE MIXERS MOUNT TO CAGE STYLE TOTES UP TO 52" WIDE

EST WT: 84-170 LBS (DEPENDING ON HP AND OPTIONS)

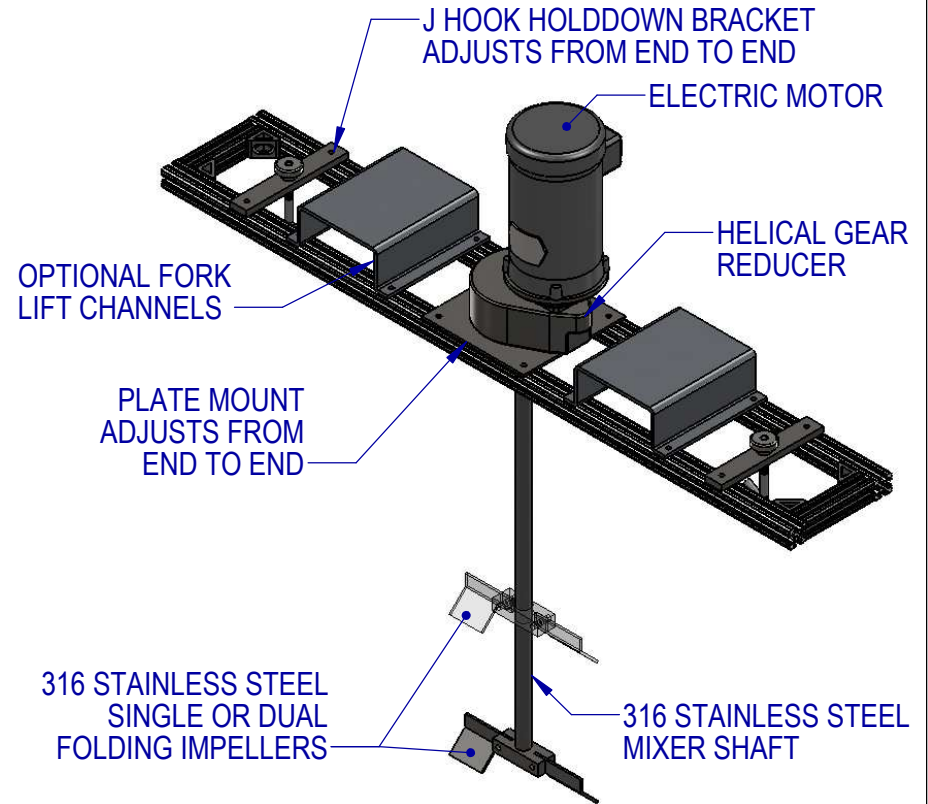

DRAWN	NAME	DATE
JDF		6/10/13
CHECKED	PIC	6/10/13

**PROPRIETARY AND CONFIDENTIAL**

THE INFORMATION CONTAINED IN THIS DRAWING IS THE SOLE PROPERTY OF FUSION FLUID EQUIPMENT LLC. ANY REPRODUCTION IN PART OR AS A WHOLE WITHOUT THE WRITTEN PERMISSION OF FUSION FLUID EQUIPMENT LLC IS PROHIBITED.

WHILE FUSION FLUID EQUIPMENT LLC STRIVES TO MAINTAIN THE INTEGRITY OF A DESIGN AS APPROVED, FUSION FLUID EQUIPMENT LLC RETAINS THE RIGHT TO MAKE MODIFICATIONS DURING THE MANUFACTURING PROCESS TO IMPROVE FIT, FORM, AND FUNCTION OF THE DESIGN WITHOUT CUSTOMER NOTIFICATION OR CONSENT.

UNLESS OTHERWISE SPECIFIED:  
DIMENSIONS ARE IN INCHES.  
NO TOLERANCE IS IMPLIED.  
DO NOT SCALE DRAWING



TITLE: <b>BRIDGE MOUNT TOTE MIXER GEAR DRIVE ELECTRIC</b>		
SIZE <b>A</b>	DWG. NO. <b>SALES-BG-#T-#</b>	REV <b>A</b>
SCALE: 1:16	WEIGHT:	SHEET 1 OF 1