

**STANDARD FEATURES:**

- PAINTED THREE PHASE, TEFC, 220/440/60 ELECTRIC MOTOR
- HELICAL GEARBOX - 5:1 REDUCTION RATIO
- 350 RPM NOMINAL OUTPUT
- 55 GALLON DRUM LID WITH TWO STANDARD NPT PORTS
- 316SS WETTED PARTS
- 1" X 30" FMB SHAFT
- SINGLE OR DUAL HYDROFOIL IMPELLERS WITH SET SCREW ATTACHMENT

**OPTIONS:**

- SINGLE PHASE TEFC MOTOR
- PREWIRED W/ TOGGLE SWITCH, CORD AND 110V PLUG
- SINGLE SPEED EXPLOSION PROOF MOTOR
- 32 Ra FINISH ON ALL WETTED PARTS

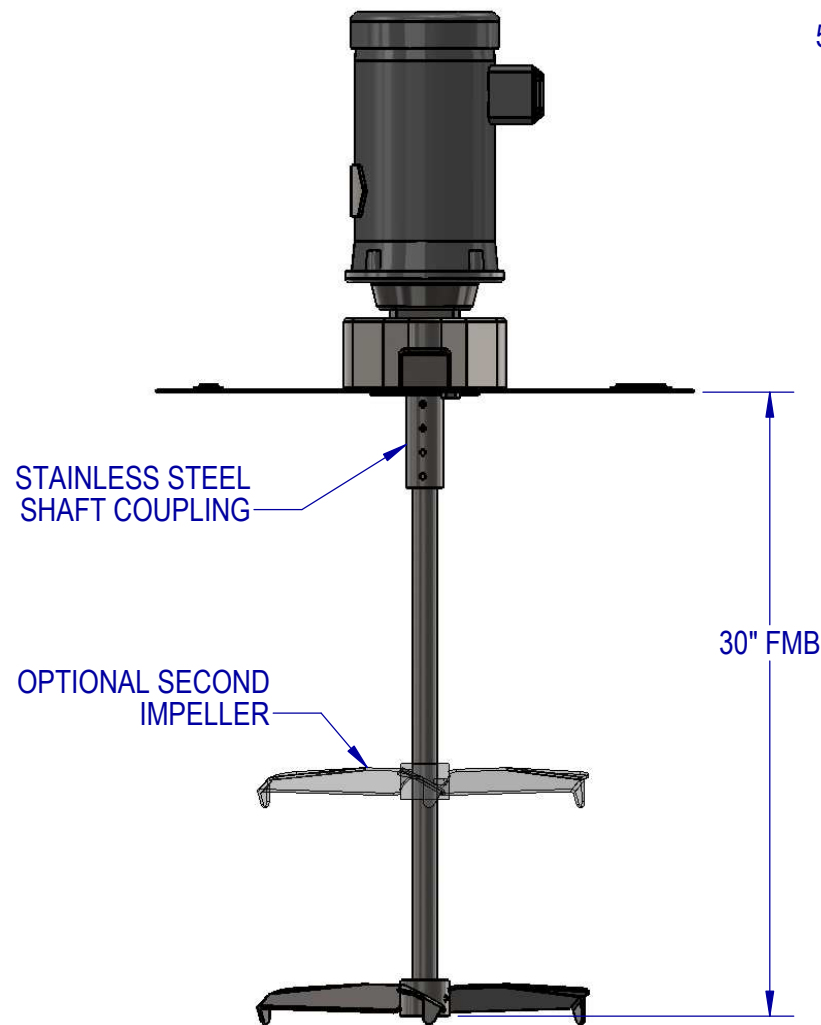

EST WT: 77-100 LBS (DEPENDING ON HP AND OPTIONS)

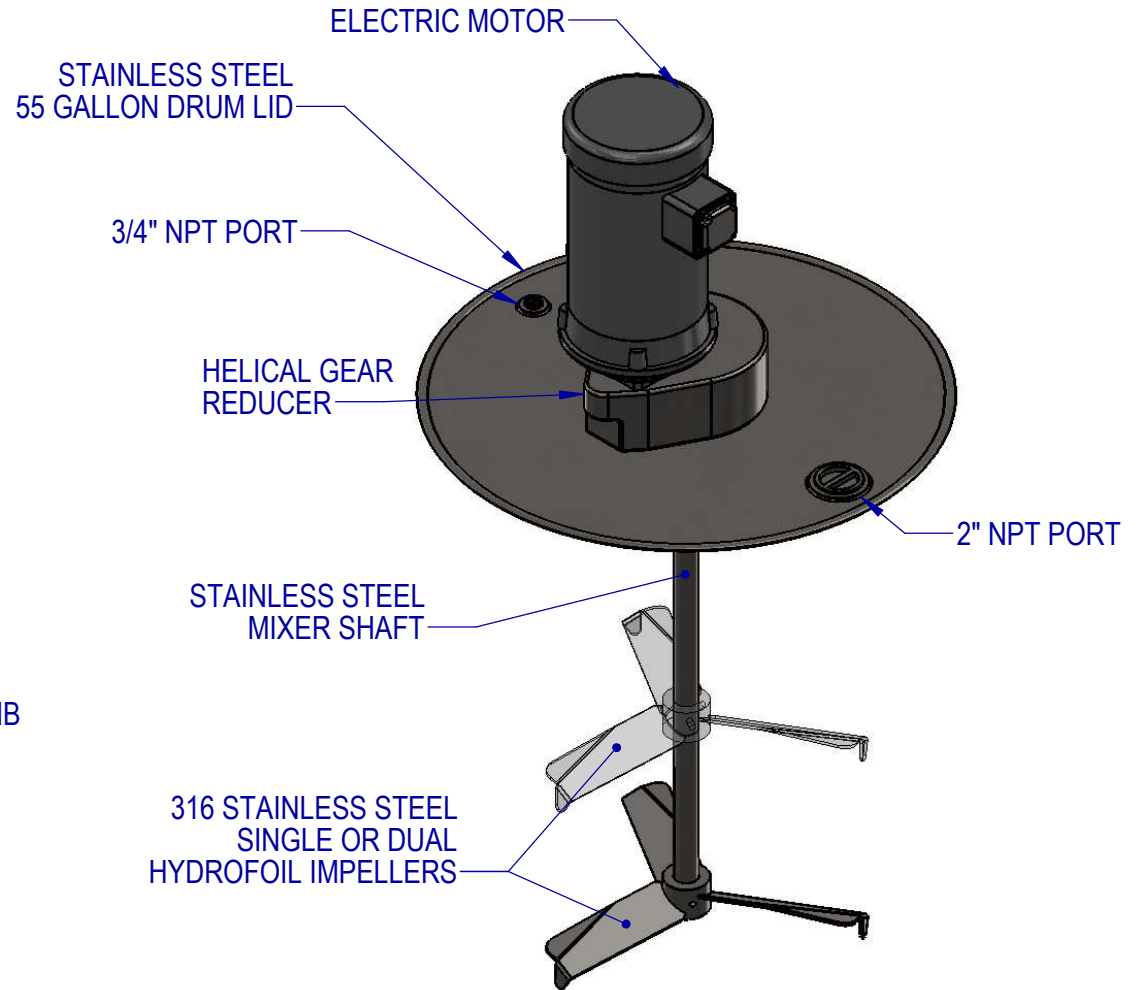

|         | NAME | DATE    |
|---------|------|---------|
| DRAWN   | JDF  | 6/19/13 |
| CHECKED | PIC  | 6/19/13 |

**PROPRIETARY AND CONFIDENTIAL**

THE INFORMATION CONTAINED IN THIS DRAWING IS THE SOLE PROPERTY OF FUSION FLUID EQUIPMENT LLC. ANY REPRODUCTION IN PART OR AS A WHOLE WITHOUT THE WRITTEN PERMISSION OF FUSION FLUID EQUIPMENT LLC IS PROHIBITED.

WHILE FUSION FLUID EQUIPMENT LLC STRIVES TO MAINTAIN THE INTEGRITY OF A DESIGN AS APPROVED, FUSION FLUID EQUIPMENT LLC RETAINS THE RIGHT TO MAKE MODIFICATIONS DURING THE MANUFACTURING PROCESS TO IMPROVE FIT, FORM, AND FUNCTION OF THE DESIGN WITHOUT CUSTOMER NOTIFICATION OR CONSENT.

UNLESS OTHERWISE SPECIFIED:  
DIMENSIONS ARE IN INCHES.  
NO TOLERANCE IS IMPLIED.  
DO NOT SCALE DRAWING



TITLE:  
**DRUM LID MIXER GEAR DRIVE WITH ELECTRIC MOTOR**

|             |                      |              |
|-------------|----------------------|--------------|
| SIZE        | DWG. NO.             | REV          |
| <b>A</b>    | <b>SALES-BG-#D-#</b> | <b>A</b>     |
| SCALE: 1:16 | WEIGHT:              | SHEET 1 OF 1 |